



## Embedded Commissioning©

OMER AKIN

Professor of Architecture and Director, AECM Programs, Carnegie Mellon

oa04@andrew.cmu.edu

### 1. Introduction

Embedded Commissioning (ECx) a new digital technology promises to transform capital project delivery (CPD) and its evaluation in the years to come. [1]. The primary strategy in ECx is to create an entirely new approach to building evaluation by merging building commissioning methods and information technologies into a new framework. Figure 1 helps visualize the ingredients of this framework and their relationships.

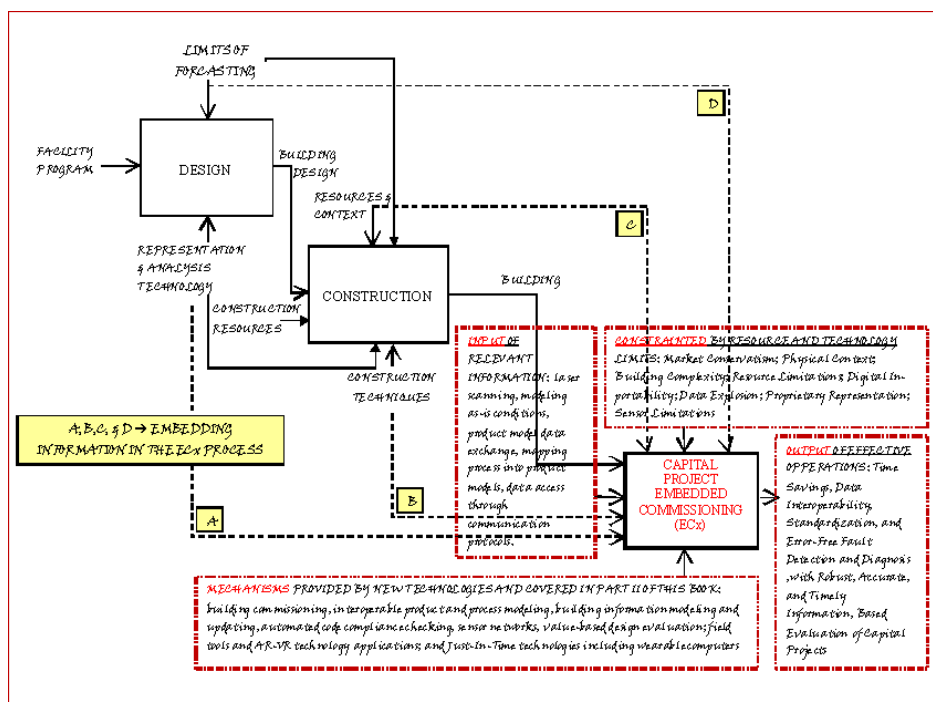

Figure 1 The IDEF0 diagram of the ECx framework

The core of the Capital Projects Delivery process consists of five stages: project programming, design, construction, project commissioning, and project operations (Figure 1). In the conventional CPD, the capital project program is the input to the design stage. In turn, the output of the design stage, or the design, is the input for the construction stage. Once the



representation. All of this would be sufficient to overcome the difficulties endemic to the traditional CPD process; streamlining its process flow, eliminating errors, and controlling the budget – the three pillars of CPD: schedule, quality, and cost.

However, this is easier said than done. In order to achieve this kind of performance first and foremost we need a ubiquitous representation. Building Information Modeling (BIM) provides a limited but competent answer to this question. We also need to achieve standardization in this representation and its mappings from format to format. Industry Foundation Classes (IFC) provides a partial answer to the first part of this requirement. Process and Product Model (PPM) mapping outlines a specific solution to the other half of the requirement. Information is dynamic and therefore we need methods and tools for updating and communication of the information encoded through BIM. Laser-based As-Is documentation and BACnet, respectively, provide potential answers. Verifying the compliance of designs and construction assemblies to codes and ordinances that govern CPD is critical to avoid silent failures as well as those not so silent, as in the case of the MGM Hotel fire. Ultimately, to make these projects responsive to change, affordable, and available to field work, we need methods for deploying and networking sensors, accurately estimating the value added by designs, and harnessing Augmented Reality information Just-In-time. This is the framework that we envision for ECx (Figure 1).

The vision of such broad innovations must include not just new digital tools and techniques but also advances in AEC practices that utilize these innovations. We envision design and engineering practices that are in the service of sound economy, environmental conservation, improved value, greater efficiency, and satisfied occupants. CPD is no longer about competence in delivering just conventional services. Engineers and Architects have to rise to the challenges of our time and insure the best economy in providing the greatest value to stakeholders. Performance needs have to be optimized against first and lifecycle cost of designs. Value must be assessed not just for the bottom line but for other tangible (health, productivity) and intangible (comfort, happiness, recognition) stakeholders benefits. Last but not least, their products must meet the three pillars of the CPD market place: quality, cost, and schedule.

The computer based information environment we envision enhances data acquisition, mining, representation, filtering, processing, transformation, access, fidelity, and communication. In terms of professional and business applications, computers have come of age. Since its early beginnings in the 60s [3], CAD (Computer Aided Design) has become the

industry standard. Today, with the advent of BIM, we enjoy almost universal acceptance of object-based representations of AEC products and processes. IFC an outgrowth of the ISO (International Organization for Standardization) has established a sound basis for universal exchange of data with reliable results. Thanks to ubiquitous internet communication, data mining and shared repositories of information are commonplace. Special applications that can translate between different data formats, compare specifications against designs, and translate between processes and products, are available just for the asking. The remaining problems of standardization, fidelity, and reliability are on their way to being part of the compendium of solutions broadly available. These developments in the digital realm provide a rich and powerful set of opportunities for engineers and architects to address the challenges of the new and emerging world of the AEC industry.

## ***2. What is Possible in the Physical World of Capital Projects?***

Buildings and building infrastructures have come a long way. Historically, building technology causes significant shifts in the way buildings are constructed. Innovations realized during the Renaissance (16th and 18th C.), Neo-Classicism (18th and 19th C.), Modernism (19th and 20th C.), or Post-Modernism (20th C.) were all based socio-cultural shifts enabled by new technologies. For instance the increase of glazing in the Renaissance façade, the flexibility of interior planning achieved through the pattern books of Neo-Classicism, the industrial mass-production of buildings achieved during the Modern Era, and the diversity of use and technology admitted into the production of buildings during Post-Modernism all are shifts in the building process ushered in by revolutionary technologies of the past [4]. Today, by virtue of the merging of building and information technologies, including the personal computer, internet, handheld and wearable computers, sensors, BIM, BACnet, IFC, and intelligent computer applications that harvest, mine, and package relevant information, we are at the cusp of a new and powerful shift in the way we build and evaluate capital projects.

In a mere two decades from now, we will be able to “dialup” information about manufacturer specifications of equipment and building parts, specific building histories, codes and ordinances applicable to specific situations, and integrated CAD-GIS databases [5], at will, from handheld and wearable devices. In addition, buildings will possess intelligence and initiate self-intervention automatically or through human contact. Buildings will be equipped with sensors, actuators, gateways, and reasoning mechanisms to be able to send precise alerts when systems reach undesirable efficiency or performance levels. Live performance

tracking that is remotely adjustable through PDAs or wearable devices will screen false positives and highlight critical Fault detection and diagnosis (FDD) results. FDD will be achieved through collaboration between self-regulating building systems and facility management and operations staff. On the web, interoperable and standardized communication connections to updated manufacturer specifications and pricing information will facilitate identification, procurement, repair, and replacement of systems.

### ***3. What is Possible in the Management World of CPD?***

The field of Facility Management will become a true collaboration between man and machine. Sensors in building system components will send alerts to facility manager when components fatigue or fail. In states of emergency, sensors will directly contact emergency response personnel, before the condition becomes critical. Sensors will become an integral part of building materials and alert occupants to moisture, termite, and other forms of undesirable penetration in the cladding system [6]. Systems for High-Tech buildings will automatically adjust exterior skin to optimize, daylight, temperature differential, moisture and sound insulation properties. Controls systems will be linked to geographic databases gathering live weather data, self-adjusting systems settings based on local conditions, operational parameters, maintenance histories, and user needs.

While many of these technologies are available even today, their seamless inter-connection is the Achilles heel of the current facility management practices. In a case study we conducted in an institutional setting, we discovered useful information about behind-the-scenes of emergency management practices. In December 2007, a water-main burst open submerging documents, furniture, and desktops in waist-deep water and threatened to do the same to the electrical panels servicing entire wings of an eight-story high, institutional building. As the clock ticked the Facility Management personnel scrambled to locate the main water valve that could control the pipe rupture. More than four hours and several false attempts at fixing the problem later, it was discovered that the faulty water main was merely passing through the building in question, to service a neighboring building, not the current one. Consequently, it was not included in the CAD files of the building but was present only in the GIS files that included the entire campus plan. This case highlights the lack of coordination that exists in BIM documentation. Handheld devices including cell phones will be used to grab information from a myriad of radio frequency threads already present in the space around us.

#### 4. A Vision of the Future State of ECx

In principle, ECx is a simple process. It compares the required performance of a capital project against its actual performance. If the desirable temperature set-point for an indoor space is 68-degrees Fahrenheit throughout the calendar year, then we should measure the temperature in that space and check against the set-point value. Complications arise because of the difficulties like:

- Is there such a room in the facility of interest?
- What is the best way to measure the ambient temperature in a room?
- How can we verify that the set-point value is satisfied?
- How can we validate that measured values provide for occupant comfort or productivity?
- What magnitude of difference between these values signifies agreement or disagreement?
- If there is disagreement, which value is incorrect, and where is the fault in the system?
- If the value is incorrect, how can we get a correct value and correct the system defect?

Inspired by these challenges and our direct experience with potential solutions to these problems we envision a future in which the following problems are addressed:

**Locating Rooms and Equipment.** Capital projects are accurately modeled in BIM systems that are interoperable with facility maintenance data and documents, these data banks are updated with As-Built and As-Modified data in a timely and accurate manner [8]. With the help of Just-In-Time (JIT) information access systems and wearable computers ECx agents will be able to locate facilities with ease and accuracy.

**Measuring Ambient Temperature.** Rooms are equipped with multiple sensors, some of which would be in garments (currently laptops also have this capability) [9], where the location and time of data gathered would be most relevant to user needs. Multiple sensors would gather data distributed over periods of time most indicative of the needs of users of the space. Automated data harvesting and distilling algorithms would summarize not only the most appropriate temperature readings but also point to anomalies and variances that matter. With the help of advanced HCI methods, this information can be conveyed to the ECx tools succinctly, accurately and JIT.

**Verifying the Set-Point Value.** Proprietary mechanisms can map their internal parameters and procedures to a neutral, standard, and universally shared representation that

can assist us in verifying the correctness and reasons for set values, without having to waste valuable time and budgetary resources of the ECx process [10].

Validating User Acceptability of Measured Values. Users are connected to the ECx process through updated Design Intent documents which are embedded in the process by virtue of interoperable and standardized data representations and tools.

Determining the Thresholds for Value Comparison. Data and criteria of evaluation for comparable buildings, live and appropriately packaged, are readily available to field workers and ECx agents. A web-wide B2B database (Business-to-Business) can accommodate comprehensive commissioning guidelines created by owners and users. Interactive checklists for different sustainability quality points would be maintained and relevant modeling software applications with version updates would be within reach of a palm device made accessible by the internet.

Ascertaining correctness of measured values. Sensors systems will eliminate local factors when necessary and perform self-reasoning and calibration.

## **5. Visions of Information Technology Futures**

The critical technologies that will make all of this possible are digital modeling of products and processes of AEC industries and the digital infrastructures that will make access, retrieval, and storage of information ubiquitous. Current trends indicate that in short order all new buildings, including the ones that were built in the last few decades will have interoperable representations of their as-built drawings, project manuals, management and operation plans, repair histories, and manufacturer's specifications. Creation and updating of all of this information will be coordinated with planners, architects, engineers and other relevant consultants of capital projects. Information will be embedded in their lifecycle process for ongoing evaluation to meet optimal performance and energy conservation goals. This process that we call Embedded Commissioning (ECx) will be enforced by licensing, and certification agencies that finance capital projects, such as US Green Building Council, US General Services Administration, US Army Corps of Engineers, and US Postal Service.

These advances will not be realized unless several technological and organizational developments in the area of standardization are realized first. Standards of interoperability must be agreed upon and adhered to by major software and hardware houses like Microsoft, Google, IBM, Intel, Autodesk, that control the development and deployment of BIM software and AEC databases including GIS and infrastructure information. We also expect that

agencies significantly contributing to the development of effective building standards like US National Institute of Standards and Technology will play a critical role in this process.

## ***6. A Vision of the World of Facilities Owners/Users and Capital Project Market Place***

Just as the CPD process and its participants operate with entirely different tools, technologies, and procedures, the owners and operators of facilities also have to adapt to this process. This is not a simple, passive adaptation. Owners and operators of capital projects have to enable this innovation through their input and continuous participation. This future world will have not only online and live data on the history of their facilities and operation/maintenance manuals; they also must have an interactive repository of best practices and troubleshooting queries for all of their equipment and building parts. They are both receivers of and contributors to this information base. As they sort out their operation, maintenance, and ECx issues, the distributed web of information repositories will capture this information and store it so that, in the future, others will be able to use it. It will provide for less fragmentation of information, increase cooperation, and be linked through standardized modeling software applications. This requires that there would be a very large database of ECx groups with sustainable practices, distributed in the digital cloud, and accessible from laptops and handheld devices. A popular ontology of AEC terms, used and supplemented by users will support this cloud utility.

Latest sensor, laser, modeling, and self-corrective technologies will be available to owners and users of capital projects. Users and their operation and maintenance personnel will be able to access, on line, standard training and certification programs for ECx. Operations and maintenance requests with links to location and relevant systems within the facility will be linked to efficient interactive troubleshooting applications. With the simple pointing of the PDA to a RFID tag, or sensor, the users will be able to access the relevant data base for uploading useful information and downloading current changes to a system in need of repair. Different aspects of the facility will be accessed for humidity-temperature penetration and termite infestation through sensors and sensor embedded cladding materials. Groups like LEED, ASHRAE, NIST and SHASE will provide presentations, examples of successful case studies, access to entities outside of the building industry, comparative analyses by consultants to government and private agencies, tax incentives for lifecycle ECx, and energy saving opportunities.

The 2011 book entitled “Embedded Commissioning of Building Systems” authored by eight leading US experts in this area, and published by Artech House, Inc. ([www.artechhouse.com](http://www.artechhouse.com)), a specialized technical book publisher, is a must-have book for those interested in making an impact in this field. Without a doubt, a future enhanced by improved quality, schedule, and budget management of capital projects awaits those members of the Architecture-Engineering-Construction sector, who are willing and excited about embracing information technologies and all that it has to offer.

## References

[1] Akin, Ö, Akinci, B., Berges, M., Bushby, S., Garrett, J., Huber, D., Lee, S.H. and Türkaslan-Bülbül, T., *Embedded Commissioning of Building Systems*, Artech House, Inc., MA, 2011.

[2] Fuhrman, A, “Pay now or pay later, Diagram motivating interoperable and persistent information models for the Architecture-Engineering-Construction, (AEC) industry, International Facility Management Association, Houston, TX.

[3] Akin, Ö, “Current Trends and Future Direction in CAD,” in H. A. Karimi, and B. Akinci (eds.) *CAD/GIS Integration: Existing and Emerging Solutions*, Auerbach, Boca Raton, 2010.

[4] Akin, Ö. “Keynote Address: I am not rem Koolhaas,” *Proceedings of the Design Communication Conference, Southern Polytechnic, Atlanta, Georgia, March 25-29 2009*

[5] Akin, Ö, “CAD and GIS Integration: Challenges and Opportunities,” in H. A. Karimi, and B. Akinci *CAD/GIS Integration: Existing and Emerging Solutions*, Auerbach, Boca Raton, 2010.

[6] Yang, B., Aksak, B., Lin, Q., and Sitti, M., “Compliant and low-cost humidity nanosensors using nanoporous polymer membranes,” *Sensors and Actuators B* 114 (2006) 254–262.

[7] Lee, S., and Akin, Ö., “Shadowing Tradespeople: Inefficiency in Maintenance Fieldwork,” *Automation in Construction*, Vol. 18, No (5), 2009, pp. 536-546

[8] Böhm, J., Becker S., and Haala N., “Model Refinement by Integrated Processing of Laser Scanning and Photogrammetry,” *Proceedings of 3D Virtual Reconstruction and Visualization of Complex Architectures (3D-Arch)*, Zurich, Switzerland, 2007

[9] Rowe, A., Berges, M., Bhatia, G., Goldman, E., Rajkumar, R., Soibelman, L., Garrett, J. H., and Moura, J. M. F., “Sensor Andrew: Large-Scale Campus-Wide Sensing and Actuation.” *IBM Journal of Research and Development*, vol. 55, no. 1 (1): 6:1 – 6:14



[10] "BACnet: A Data Communication Protocol for Building Automation and Control Networks," ANSI/ASHRAE Standard 135, American Society of Heating, Refrigerating, and Air-Conditioning Engineers, 2010

[11] Fisk, W. J., "Health and Productivity Gains from Better Indoor Environments and their Relationship with Building Energy Efficiency," Annual Review of Energy and the Environment, Vol. 25, November 2000, pp.537-566

[12] Akinci, B., Garrett, J., and Akin, Ö., Identification of Functional Requirements and Possible Approaches for Self-Configuring Intelligent Building Systems, Final Report Submitted to Steven Bushby, NIST, 100 Bureau Drive, Stop 8631, Gaithersburg, MD 20899-8631